

## AMALGAMATION 3

FLOORS 7-27

3 BEDROOMS + DEN  
3.5 BATHROOMS

LIVING: 3,604 SF  
TERRACE: 786 SF  
TOTAL: 4,390 SF

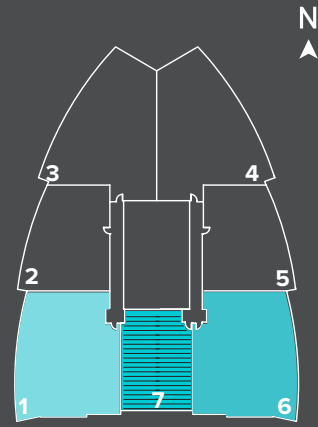

**BLEU CIEL**  
SKY-RISE LIVING

SALES CENTER: 3008 N HARWOOD ST, HARWOOD, DALLAS, TX 75201  
EXCLUSIVELY MARKETED AND SOLD BY HARWOOD LIVING

**HARWOOD  
LIVING**

The Developer reserves the right to make modifications and changes to the information contained herein. Renderings, photos and sketches are representational and are not necessarily accurate. Dimensions, sizes, specifications, layouts and materials are approximate only and subject to change without notice. The dimensions and square footages of the unit(s) that will be conveyed will differ and will be based upon the paint to paint measurements method as more particularly described in the Declaration and the Condominium Information Statement. Obtain the Property Report required by Federal law and read it before signing anything. No Federal agency has judged the merits or value, if any, of this property.



EQUAL HOUSING  
OPPORTUNITY

